

STYLEA

5920XOI065L51-10 DOM23

EAN 4031582342581

Swivel castor, housing made of Polyamide, with blind hole fitting. Wheel centre made of Polyamide, plain bearing, electric conductive



BETTER MOBILITY. BETTER LIFE.



Picture may differ from original product

Technical Data

Wheel diameter	65 mm
Wheel width	8 mm
Castor width	43 mm
Centre hole	10 mm
Dome-Ø	23 mm
Offset	25 mm
Swivel Interference	106 mm
Overall height	68 mm
Temperature	- 20 / + 60 °C
Standard	EN_12528
Weight	0.136 kg
Swivel Radius	53 mm
Hardness of tread	Shore D 65
Load capacity	50 kg
Load capacity (static)	100 kg

Structure & Mounting

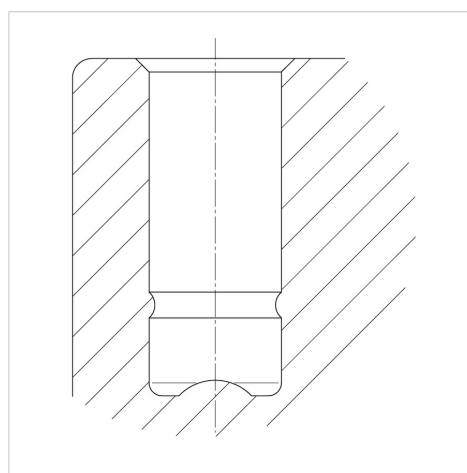

Advantages at a glance

Roll performance	● ● ● ○ ○
Movement noise	● ● ● ○ ○
Attrition	● ● ● ● ●
Corrosion resistance	● ● ● ● ○