

AGILA TWIN

2977POO75P30-10,3

EAN 4031582428247

Swivel caster with total lock, trailing end of caster, housing made of pressed steel, bright zinc plated, blue passivated, double ball bearing swivel head, wheel axle with nut Wheel center made of Polypropylene, plain bearing



BETTER MOBILITY. BETTER LIFE.



Picture may differ from original product

Technical Data

Wheel diameter	2.95 in
Wheel width	0.98 in
Center hole	0.39 in
Offset	1.24 in
Swivel Interference	7.80 in
Overall height	3.90 in
Load capacity (dynamic)	220 lbs
Load capacity (static)	440 lbs

Structure & Mounting

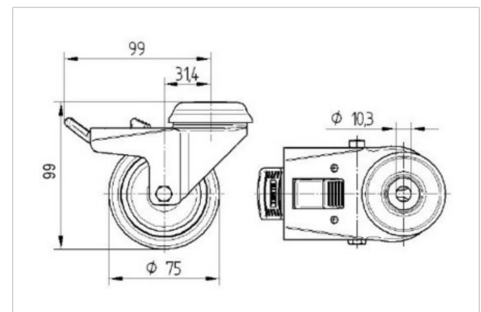

Advantages at a glance

Roll performance	○ ○ ○ ○ ○
Movement noise	○ ○ ○ ○ ○
Attrition	○ ○ ○ ○ ○
Corrosion resistance	○ ○ ○ ○ ○