

# AGILA

2475PJI050P40

EAN 4031582050035

Swivel caster with wheel brake, housing made of pressed steel, bright zinc plated, blue passivated, double ball bearing swivel head, axle riveted, plate fitting. Wheel center made of Polypropylene, Tread: TENTEprene (thermoplastic rubber), grey non-marking, plain bearing



BETTER MOBILITY. BETTER LIFE.



Picture may differ from original product

## Technical Data

Wheel diameter	1.97 in
Wheel width	0.75 in
Caster width	1.69 in
Plate size	2.36 x 2.36 in
Plate hole centers	1.89/1.50 x 1.89/1.50 in
Plate hole	0.25 in
Dome-Ø	1.61 in
Offset	0.94 in
Swivel Interference	6.46 in
Overall height	2.72 in
Temperature	- 4 / + 140 °F
Standard	EN 12530
Weight	0.423 lbs
Swivel Radius	3.23 in
Hardness of tread	Shore A 87
Load capacity (dynamic)	90 lbs
Load capacity (static)	175 lbs

## Structure & Mounting

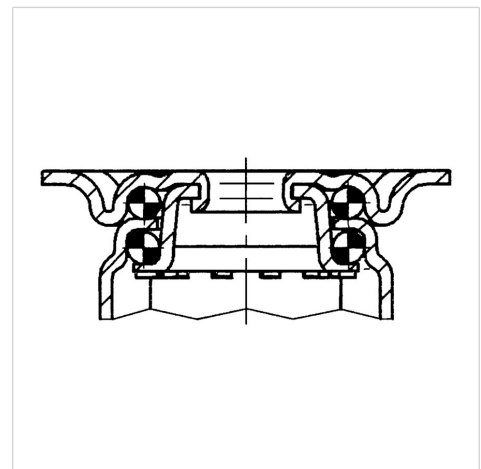

## Advantages at a glance

Roll performance	● ● ● ○ ○
Movement noise	● ● ● ○ ○
Attrition	● ● ● ○ ○
Corrosion resistance	● ● ● ○ ○

