

AGILA TWIN

2977DIK075P30-10

EAN 4031582302899

Swivel caster with total lock, trailing end of caster, housing made of pressed steel, bright zinc plated, blue passivated, double ball bearing swivel head, wheel axle with nut, bolt hole. Wheel center made of pressed steel, Tread: solid rubber, grey non-marking, with threadguards, cone ball bearing



BETTER MOBILITY. BETTER LIFE.



Picture may differ from original product

Technical Data

Wheel diameter	2.95 in
Wheel width	0.98 in
Caster width	2.80 in
Center hole	0.41 in
Dome-Ø	2.56 in
Offset	1.23 in
Swivel Interference	7.80 in
Overall height	3.90 in
Temperature	- 4 / + 185 °F
Standard	EN 12530
Weight	1.916 lbs
Swivel Radius	3.90 in
Hardness of tread	Shore A 80
Load capacity (dynamic)	220 lbs
Load capacity (static)	440 lbs

Advantages at a glance

Roll performance	● ● ● ○ ○
Movement noise	● ● ● ○ ○
Attrition	● ● ● ○ ○
Corrosion resistance	● ● ● ○ ○

Dimensions

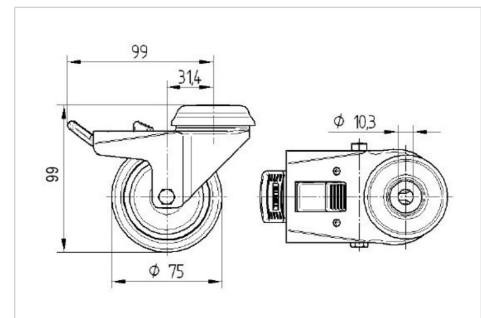

Structure & Mounting

