

ZETA

4681TOP125P63

EAN 4031582308037

Swivel caster with directional lock, housing made of very heavy pressed steel, reinforced, bright zinc plated, blue passivated, sealed swivel double ball bearing, reinforced and heat-treated ball covers, riveted king pin, wheel axle with nut and dust ring with integrated grease nipple., plate fitting. Wheel center made of Polyamide, heavy duty, precision ball bearing



BETTER MOBILITY. BETTER LIFE.



Picture may differ from original product

Technical Data

Wheel diameter	4.92 in
Wheel width	1.97 in
Caster width	3.78 in
Plate size	5.39 x 4.13 in
Plate hole centers	4.13 x 3.15/2.95 in
Plate hole	0.43 in
Dome-Ø	3.78 in
Offset	2.17 in
Swivel Interference	9.06 in
Overall height	6.46 in
Temperature	- 22 / + 176 °F
Standard	EN 12532
Weight	6.188 lbs
Hardness of tread	Shore D 75
Load capacity (dynamic)	1545 lbs
Load capacity (static)	3085 lbs

Dimensions

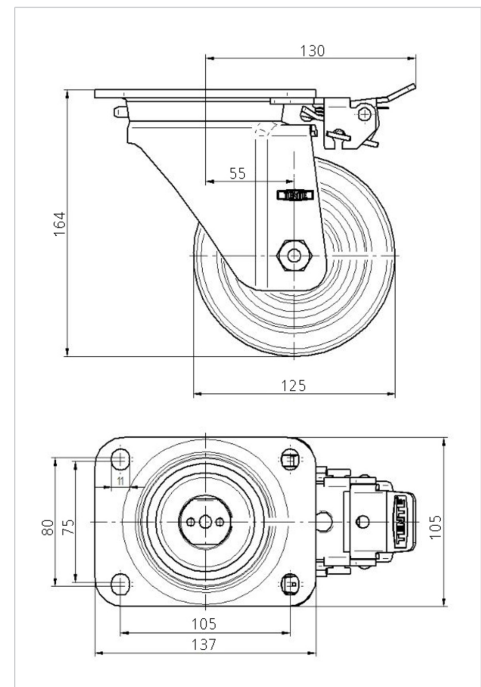

Structure & Mounting

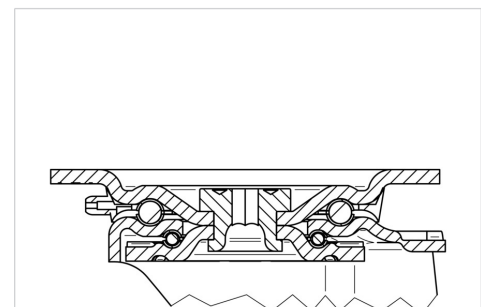

Advantages at a glance

Roll performance	● ● ● ● ●
Movement noise	● ○ ○ ○ ○
Attrition	● ● ● ● ●
Corrosion resistance	● ● ● ○ ○

ZETA

4681TOP125P63

EAN 4031582308037



BETTER MOBILITY. BETTER LIFE.

Structure & Mounting

