

# KAPPA

## 9681ITP150P63 Flat

EAN 4031582315585

Swivel caster with directional lock, housing and plate steel-welded, bright zinc plated, blue passivated, sealed single swivel double ball bearing, threaded king pin and locking nut secured, grease nipple, wheel axle with nut, plate fitting. Wheel center made of Aluminum, Tread: Polyurethane, casted, precision ball bearing



BETTER MOBILITY. BETTER LIFE.



Picture may differ from original product

### Technical Data

Wheel diameter	5.91 in
Wheel width	1.97 in
Caster width	4.33 in
Plate size	5.31 x 4.33 in
Plate hole centers	4.13 x 3.15/2.95 in
Plate hole	0.43 in
Dome-Ø	4.37 in
Offset	2.28 in
Swivel Interference	10.83 in
Overall height	7.87 in
Temperature	+ 14 / + 140 °F
Standard	EN 12532
Weight	9.769 lbs
Swivel Radius	5.41 in
Hardness of tread	Shore A 92
Load capacity (dynamic)	1435 lbs
Load capacity (static)	2865 lbs

### Advantages at a glance

Roll performance	● ● ● ○ ○
Movement noise	● ● ● ○ ○
Attrition	● ● ● ● ○
Corrosion resistance	● ● ● ○ ○

### Dimensions

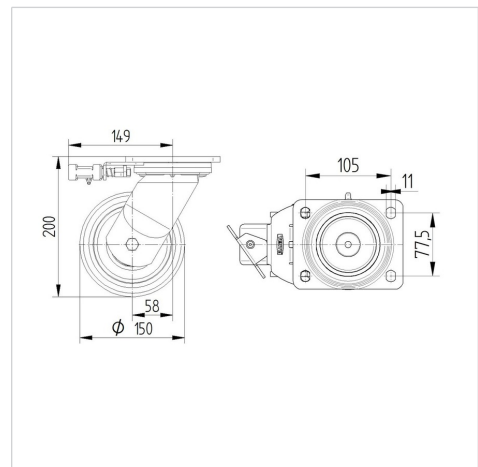

### Structure & Mounting

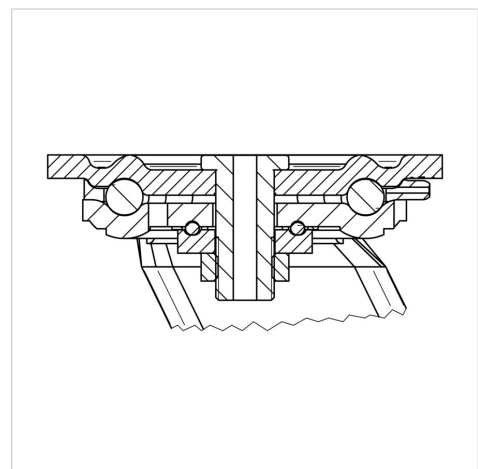

# KAPPA

## 9681ITP150P63 Flat

EAN 4031582315585



BETTER MOBILITY. BETTER LIFE.

### Structure & Mounting

