

KAPPA

9651ITP200P63 Flat

EAN 4031582314595

Swivel caster with directional lock, housing and plate steel-welded, bright zinc plated, blue passivated, sealed swivel bearing with dual purpose bearing and tapered roller bearing, threaded king pin and locking nut secured, grease nipple, wheel axle with nut, plate fitting. Wheel center made of Aluminum, Tread: Polyurethane, casted, precision ball bearing



BETTER MOBILITY. BETTER LIFE.



Picture may differ from original product

Technical Data

| | |
|-------------------------|---------------------|
| Wheel diameter | 7.87 in |
| Wheel width | 1.97 in |
| Caster width | 4.33 in |
| Plate size | 5.31 x 4.33 in |
| Plate hole centers | 4.13 x 3.15/2.95 in |
| Plate hole | 0.43 in |
| Dome-Ø | 4.37 in |
| Offset | 2.32 in |
| Swivel Interference | 12.60 in |
| Overall height | 9.65 in |
| Temperature | + 14 / + 140 °F |
| Standard | EN 12532 |
| Weight | 11.061 lbs |
| Swivel Radius | 6.30 in |
| Hardness of tread | Shore A 92 |
| Load capacity (dynamic) | 1765 lbs |
| Load capacity (static) | 3525 lbs |

Advantages at a glance

| | |
|----------------------|-----------|
| Roll performance | ● ● ● ● ○ |
| Movement noise | ● ● ● ○ ○ |
| Attrition | ● ● ● ● ○ |
| Corrosion resistance | ● ● ● ○ ○ |

Dimensions

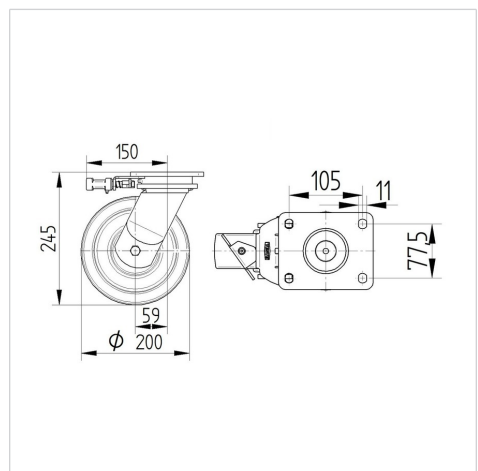

Structure & Mounting

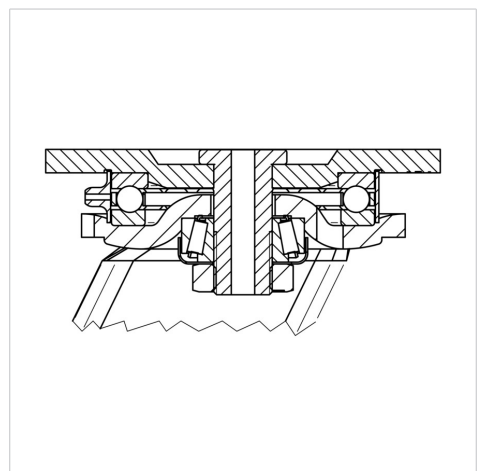

KAPPA

9651ITP200P63 Flat

EAN 4031582314595



BETTER MOBILITY. BETTER LIFE.

Structure & Mounting

