

KAPPA

9652FTP300P64

EAN 4031582314823

Swivel caster with total lock, leading end of caster, housing and plate steel-welded, bright zinc plated, blue passivated, sealed swivel bearing with dual purpose bearing and tapered roller bearing, threaded king pin and locking nut secured, grease nipple, wheel axle with nut, plate fitting. Wheel center made of cast iron, Tread: Polyurethane, casted, precision ball bearing



BETTER MOBILITY. BETTER LIFE.



Picture may differ from original product

Technical Data

Wheel diameter	11.81 in
Wheel width	3.15 in
Caster width	5.51 in
Plate size	6.89 x 5.51 in
Plate hole centers	5.51 x 4.13 in
Plate hole	0.59 in
Dome-Ø	5.51 in
Offset	2.99 in
Swivel Interference	18.11 in
Overall height	13.98 in
Temperature	+ 14 / + 140 °F
Standard	EN 12533
Weight	49.220 lbs
Swivel Radius	9.06 in
Hardness of tread	Shore A 92
Load capacity (dynamic)	4410 lbs
Load capacity (static)	8820 lbs

Advantages at a glance

Roll performance	● ● ● ● ○
Movement noise	● ● ● ○ ○
Attrition	● ● ● ● ○
Corrosion resistance	● ● ● ○ ○

Dimensions

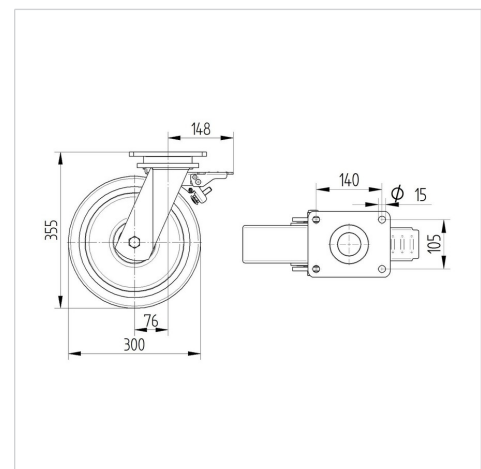

Structure & Mounting

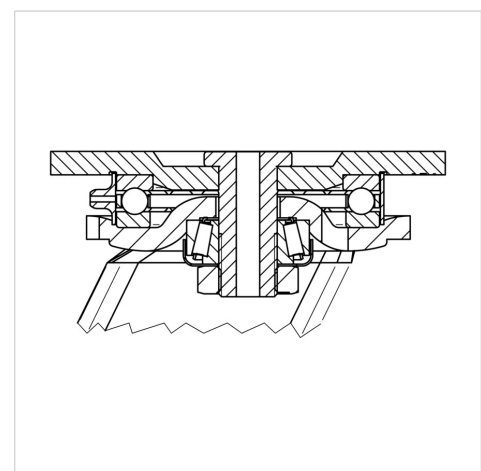

KAPPA

9652FTP300P64

EAN 4031582314823



BETTER MOBILITY. BETTER LIFE.

Structure & Mounting

