

AGILA

2470DIK050P40

EAN 4031582010107

Swivel caster, housing made of pressed steel, bright zinc plated, blue passivated, double ball bearing swivel head, wheel axle with nut, plate fitting. Wheel center made of pressed steel, Tread: solid rubber, grey non-marking, with threadguards, cone ball bearing



BETTER MOBILITY. BETTER LIFE.



Picture may differ from original product

Technical Data

Wheel diameter	1.97 in
Wheel width	0.75 in
Caster width	1.69 in
Plate size	2.36 x 2.36 in
Plate hole centers	1.89/1.50 x 1.89/1.50 in
Plate hole	0.25 in
Dome-Ø	1.61 in
Offset	0.94 in
Swivel Interference	3.86 in
Overall height	2.72 in
Temperature	- 4 / + 185 °F
Standard	EN 12530
Weight	0.534 lbs
Swivel Radius	1.93 in
Hardness of tread	Shore A 80
Load capacity (dynamic)	90 lbs
Load capacity (static)	175 lbs

Dimensions

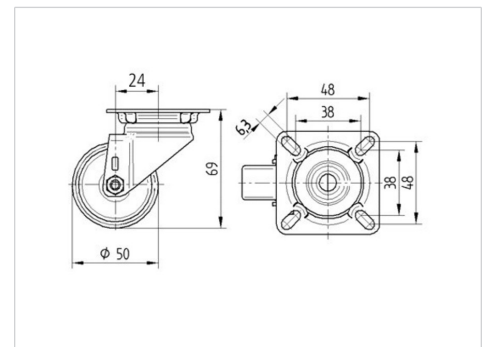

Structure & Mounting

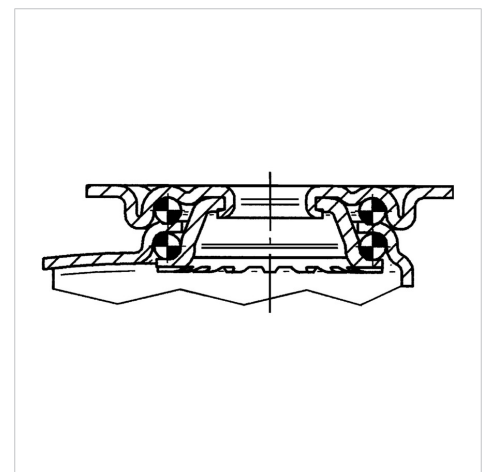

Advantages at a glance

Roll performance	● ● ● ○ ○
Movement noise	● ● ● ○ ○
Attrition	● ● ● ○ ○
Corrosion resistance	● ● ● ○ ○

AGILA

2470DIK050P40

EAN 4031582010107



BETTER MOBILITY. BETTER LIFE.

Structure & Mounting

