

AGILA

2477PJO125R47-36-40

EAN 4031582326543

Swivel caster with total lock, trailing end of caster, housing made of pressed steel, bright zinc plated, blue passivated, double ball bearing swivel head, wheel axle with nut, expandable fitting (square). Wheel center made of Polypropylene, Tread: TENTEprene (thermoplastic rubber), grey non-marking, plain bearing. Please indicate required tube diameter when ordering.



BETTER MOBILITY. BETTER LIFE.



Picture may differ from original product

Technical Data

Wheel diameter	4.92 in
Wheel width	1.26 in
Caster width	2.36 in
Expandable fitting- \varnothing	1.42 - 1.57 in
Dome- \varnothing	2.36 in
Offset	1.61 in
Swivel Interference	10.31 in
Overall height	6.40 in
Temperature	- 14 / + 104 °F
Standard	EN 12530
Weight	2.207 lbs
Swivel Radius	5.16 in
Hardness of tread	Shore A 87
Load capacity (dynamic)	220 lbs
Load capacity (static)	440 lbs

Advantages at a glance

Roll performance	● ● ● ○ ○
Movement noise	● ● ● ○ ○
Attrition	● ● ● ○ ○
Corrosion resistance	● ● ● ○ ○

Dimensions

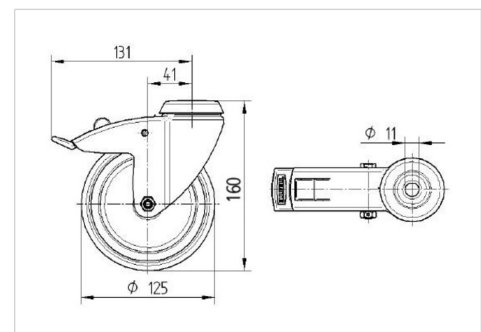

Structure & Mounting

