

AGILA

1475PAO050P30-11

EAN 4031582338485

Swivel caster with wheel brake, housing made of pressed steel, bright zinc plated, blue passivated, double ball bearing swivel head, bolt hole.
Wheel center made of Polypropylene, Tread: Polyurethane, plain bearing



BETTER MOBILITY. BETTER LIFE.



Picture may differ from original product

Technical Data

| | |
|-------------------------|----------------|
| Wheel diameter | 1.97 in |
| Wheel width | 0.75 in |
| Caster width | 1.73 in |
| Center hole | 0.43 in |
| Dome-Ø | 1.61 in |
| Offset | 0.98 in |
| Swivel Interference | 5.04 in |
| Overall height | 2.76 in |
| Temperature | - 4 / + 140 °F |
| Standard | EN 12530 |
| Weight | 0.397 lbs |
| Swivel Radius | 2.52 in |
| Hardness of tread | Shore D 40 |
| Load capacity (dynamic) | 90 lbs |
| Load capacity (static) | 175 lbs |

Structure & Mounting

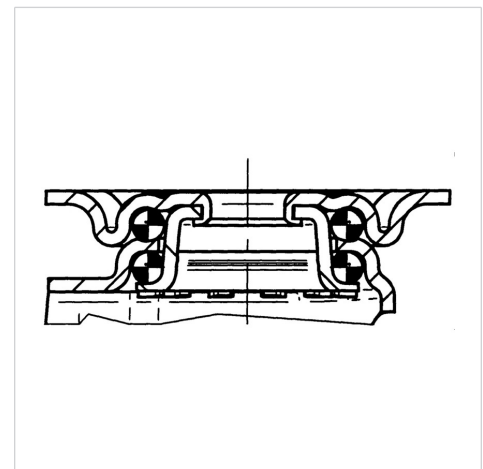

Advantages at a glance

| | |
|----------------------|-----------|
| Roll performance | ● ● ● ○ ○ |
| Movement noise | ● ● ● ○ ○ |
| Attrition | ● ● ● ● ○ |
| Corrosion resistance | ● ● ● ○ ○ |