

ZETA

4687ITP250P63 SH80

EAN 4031582337617

Swivel caster with total lock, trailing end of caster, housing made of very heavy pressed steel, reinforced, bright zinc plated, blue passivated, sealed swivel double ball bearing, reinforced and heat-treated ball covers, riveted king pin, wheel axle with nut and dust ring with integrated grease nipple., plate fitting. Wheel center made of Aluminum, Tread: Polyurethane, casted, precision ball bearing



BETTER MOBILITY. BETTER LIFE.



Picture may differ from original product

Technical Data

Wheel diameter	9.84 in
Wheel width	1.97 in
Caster width	3.78 in
Plate size	5.39 x 4.13 in
Plate hole centers	4.13 x 3.15/2.95 in
Plate hole	0.43 in
Dome-Ø	3.78 in
Offset	2.17 in
Swivel Interference	14.17 in
Overall height	11.42 in
Temperature	+ 14 / + 140 °F
Standard	EN 12532
Weight	10.401 lbs
Swivel Radius	7.09 in
Hardness of tread	Shore A 80
Load capacity (dynamic)	1765 lbs
Load capacity (static)	3525 lbs

Advantages at a glance

Roll performance	● ● ● ● ○
Movement noise	● ● ● ● ○
Attrition	● ● ● ● ○
Corrosion resistance	● ● ● ○ ○

Dimensions

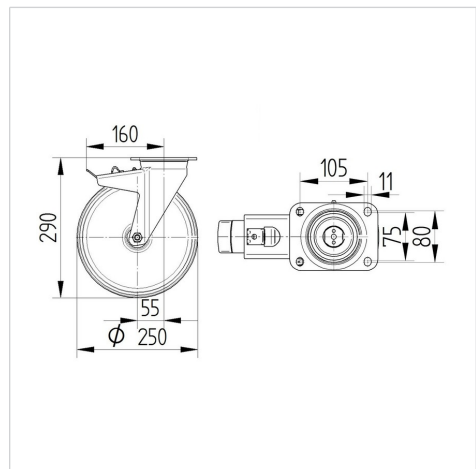

Structure & Mounting

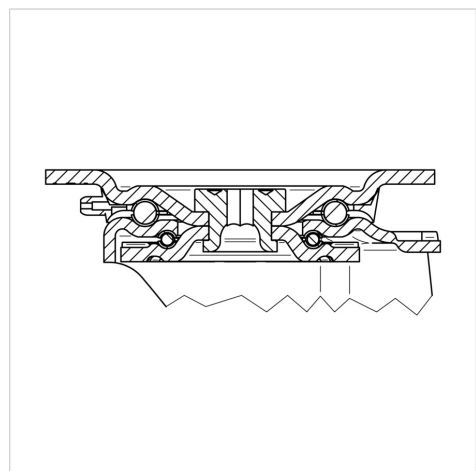

ZETA

4687ITP250P63 SH80

EAN 4031582337617



BETTER MOBILITY. BETTER LIFE.

Structure & Mounting

