

INTEGRAL TWIN

2940USX100R05-28

EAN 4031582341195

Swivel caster, Frame made of pressed steel, precision ball bearing in swivel head, housing with synthetic cover, solid plug fitting. Wheel center made of Polyamide, tread made of injected Polyurethane, with threadguards, precision ball bearing, sealed
 Hint: TÜV Süd certified product. Washable casters must be sealed in the fitting area by the hospital bed manufacturer.



BETTER MOBILITY. BETTER LIFE.



Picture may differ from original product

Technical Data

Wheel diameter	3.94 in
Wheel width	0.59 in
Caster width	2.48 in
Bolt-Ø	1.10 in
Bolt length	1.77 in
Dome-Ø	2.42 in
Offset	1.22 in
Swivel Interference	6.69 in
Overall height	5.08 in
Temperature	- 13 / - 13 °F
Standard	EN 12531
Weight	2.429 lbs
Swivel Radius	3.35 in
Hardness of tread	Shore D 40
Load capacity (dynamic)	275 lbs
Load capacity (static)	825 lbs

Structure & Mounting

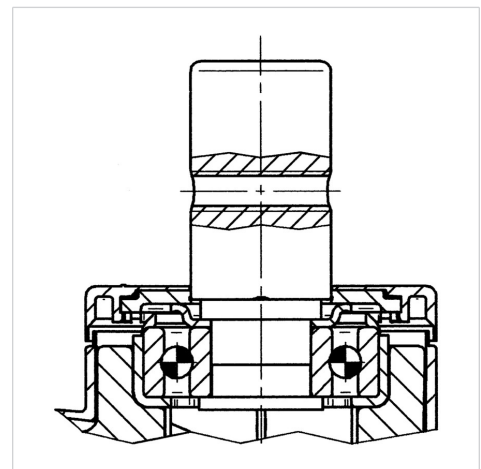

Advantages at a glance

Roll performance	● ● ● ● ●
Movement noise	● ● ● ○ ○
Attrition	● ● ● ○ ○
Corrosion resistance	● ● ● ○ ○

INTEGRAL TWIN

2940USX100R05-28

EAN 4031582341195



BETTER MOBILITY. BETTER LIFE.

Structure & Mounting



Design Award Winner
German Designer Club



reddot design award
winner



TUV
SUD
Production monitored
Type tested