

LINEA

5925UAP075L51-10 RAL7001

EAN 4031582357684

Swivel caster with wheel brake, housing made of Polyamide, with blind hole fitting. Wheel center made of Polyamide, Tread: Polyurethane, precision ball bearing



BETTER MOBILITY. BETTER LIFE.



Picture may differ from original product

Technical Data

Wheel diameter	2.95 in
Wheel width	0.59 in
Caster width	2.17 in
Center hole	0.39 in
Dome-Ø	1.18 in
Offset	0.91 in
Swivel Interference	6.38 in
Overall height	2.97 in
Temperature	- 4 / + 140 °F
Standard	EN 12528
Weight	0.432 lbs
Swivel Radius	3.19 in
Hardness of tread	Shore A 92
Load capacity (dynamic)	220 lbs
Load capacity (static)	440 lbs

Structure & Mounting

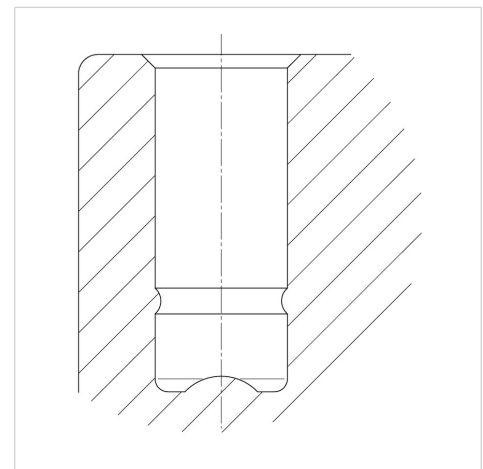

Advantages at a glance

Roll performance	● ● ● ○ ○
Movement noise	● ● ● ○ ○
Attrition	● ● ● ○ ○
Corrosion resistance	● ● ● ● ○