

# KAPPA

## 9652TOP125P63

EAN 4031582348781

Swivel caster with total lock, leading end of caster, housing and plate steel-welded, bright zinc plated, blue passivated, sealed swivel bearing with dual purpose bearing and tapered roller bearing, threaded king pin and locking nut secured, grease nipple, wheel axle with nut, plate fitting. Wheel center made of Polyamide, heavy duty, precision ball bearing



BETTER MOBILITY. BETTER LIFE.



Picture may differ from original product

### Technical Data

Wheel diameter	4.92 in
Wheel width	1.97 in
Caster width	4.57 in
Plate size	5.31 x 4.33 in
Plate hole centers	4.13 x 3.15/2.95 in
Plate hole	0.43 in
Dome-Ø	4.37 in
Offset	1.89 in
Swivel Interference	8.86 in
Overall height	6.69 in
Temperature	- 22 / + 176 °F
Standard	EN 12533
Weight	9.264 lbs
Swivel Radius	4.43 in
Hardness of tread	Shore D 75
Load capacity (dynamic)	1545 lbs
Load capacity (static)	3085 lbs

### Advantages at a glance

Roll performance	● ● ● ● ●
Movement noise	● ○ ○ ○ ○
Attrition	● ● ● ● ●
Corrosion resistance	● ● ● ○ ○

### Dimensions

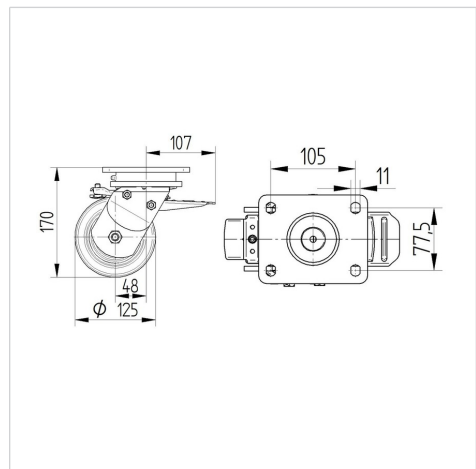

### Structure & Mounting

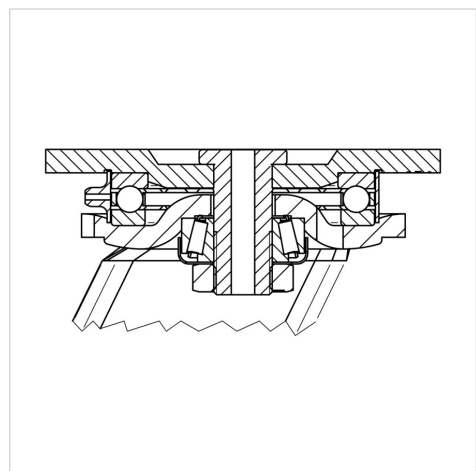

# KAPPA

9652TOP125P63

EAN 4031582348781



BETTER MOBILITY. BETTER LIFE.

## Structure & Mounting

