

# AGILA

2470YGO100P30-13

EAN 4031582365153

Swivel caster, housing made of pressed steel, bright zinc plated, blue passivated, double ball bearing swivel head, wheel axle with nut, bolt hole. Wheel center made of Polypropylene, electric conductive, Tread: TENTEprene (thermoplastic rubber), grey non-marking, plain bearing casters can be mounted with standard screws; various length screws can be used.



BETTER MOBILITY. BETTER LIFE.



Picture may differ from original product

## Technical Data

Wheel diameter	3.94 in
Wheel width	1.26 in
Caster width	2.36 in
Center hole	0.51 in
Dome-Ø	2.36 in
Offset	1.50 in
Swivel Interference	6.93 in
Overall height	5.31 in
Temperature	- 4 / + 140 °F
Standard	EN 12530
Weight	1.184 lbs
Swivel Radius	3.46 in
Hardness of tread	Shore A 87
Load capacity (dynamic)	175 lbs
Load capacity (static)	355 lbs

## Structure & Mounting

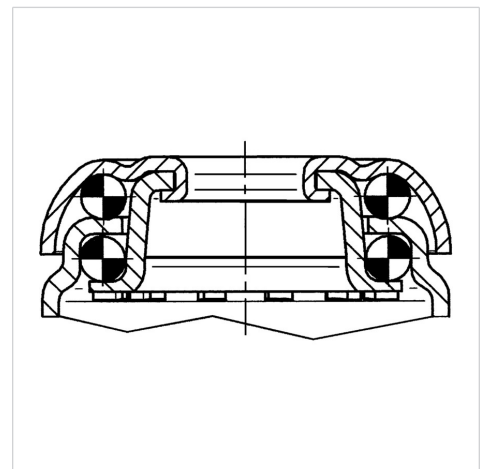

## Advantages at a glance

Roll performance	● ● ● ○ ○
Movement noise	● ● ● ○ ○
Attrition	● ● ● ○ ○
Corrosion resistance	● ● ● ○ ○