

AGILA TWIN

1970PIP075P50 TFR

EAN 4031582400243

Swivel caster, housing made of pressed steel, bright zinc plated, blue passivated, double ball bearing swivel head, wheel axle with nut, plate fitting. Wheel center made of Polypropylene, Tread: solid rubber, grey non-marking, precision ball bearing



BETTER MOBILITY. BETTER LIFE.



Picture may differ from original product

Technical Data

Wheel diameter	2.95 in
Wheel width	0.98 in
Plate size	3.03 x 2.64 in
Plate hole centers	2.42/2.20 x 2.03/1.83 in
Plate hole	0.33 in
Offset	1.24 in
Swivel Interference	5.43 in
Overall height	3.90 in
Temperature	- 4 / + 140 °F
Standard	EN 12530
Weight	0.331 lbs
Swivel Radius	2.71 in
Hardness of tread	Shore A 87
Load capacity (dynamic)	175 lbs
Load capacity (static)	355 lbs

Structure & Mounting

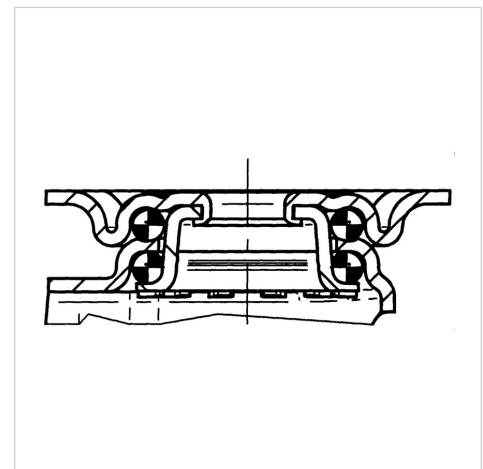

Advantages at a glance

Roll performance	● ● ● ○ ○
Movement noise	● ● ● ○ ○
Attrition	● ● ● ● ○
Corrosion resistance	● ● ● ○ ○

AGILA TWIN

1970PIP075P50 TFR

EAN 4031582400243



BETTER MOBILITY. BETTER LIFE.

Structure & Mounting

