

LINEA

594CUAC125P30-11 RAL9002

EAN 4031582398533

Swivel caster with combined kick pedal for directional- and total lock, housing made of Polyamide, precision ball bearing in swivel head, bolt hole. Wheel centre made of polyamide, tread made of polyurethane, two INOX precision ball bearings, sealed, washable



BETTER MOBILITY. BETTER LIFE.



Picture may differ from original product

Technical Data

Wheel diameter	4.92 in
Wheel width	0.79 in
Caster width	3.23 in
Center hole	0.43 in
Dome-Ø	2.05 in
Offset	1.57 in
Swivel Interference	10.16 in
Overall height	5.63 in
Temperature	-4/+140 °F
Standard	EN 12530
Weight	2.172 lbs
Swivel Radius	5.08 in
Hardness of tread	Shore A 92
Load capacity (dynamic)	245 lbs
Load capacity (static)	485 lbs

Advantages at a glance

Roll performance	● ● ● ● ●
Movement noise	● ● ● ○ ○
Attrition	● ● ● ● ○
Corrosion resistance	● ● ● ● ○

Dimensions

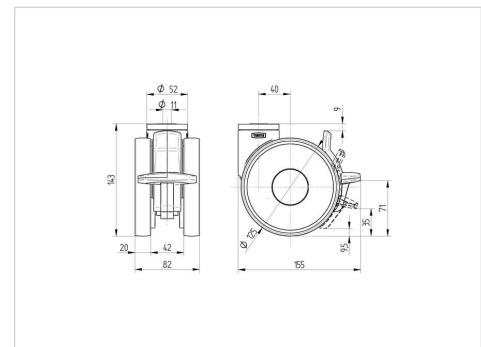

Structure & Mounting

