

LEVINA

5381UAC125R05-25.4

EAN 4031582426373

Swivel caster with directional lock, housing made from high grade synthetic materials with metal parts made of Stainless Steel, double ball bearing swivel head, solid plug fitting. Wheel centre made of polyamide, tread made of polyurethane, two INOX precision ball bearings, sealed, washable



BETTER MOBILITY. BETTER LIFE.



Picture may differ from original product

Technical Data

Wheel diameter	4.92 in
Wheel width	1.26 in
Bolt-Ø	1.00 in
Bolt length	1.77 in
Offset	1.50 in
Swivel Interference	7.91 in
Overall height	6.34 in
Temperature	- 14 / + 104 °F
Standard	EN 12530
Swivel Radius	3.96 in
Hardness of tread	Shore A 92
Load capacity (dynamic)	220 lbs
Load capacity (static)	440 lbs

Advantages at a glance

Roll performance	● ● ● ○ ○
Movement noise	● ● ● ● ○
Attrition	● ● ● ● ○
Corrosion resistance	● ● ● ● ●

Dimensions

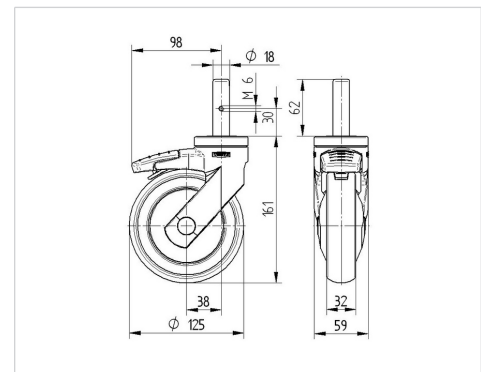

Structure & Mounting

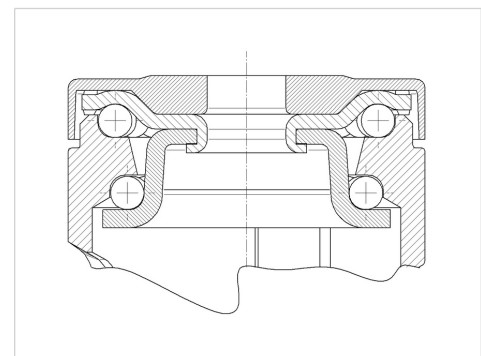

PRODUCT INFORMATION

LEVINA

5381UAC125R05-25.4

EAN 4031582426373



BETTER MOBILITY. BETTER LIFE.

Structure & Mounting

