

# AGILA TWIN

2975UAK050P40

EAN 4031582302837

Swivel castor with wheel brake, housing made of pressed steel, bright zinc plated, blue passivated, double ball bearing swivel head, wheel axle with nut, plate fitting. Wheel centre made of Polyamide, Tread: Polyurethane, with threadguards, cone ball bearing



BETTER MOBILITY. BETTER LIFE.



Picture may differ from original product

## Technical Data

Wheel diameter	50 mm
Wheel width	20 mm
Castor width	57 mm
Size of Plate	60 x 60 mm
Plate hole centres	48/38 x 48/38 mm
Plate hole	6,3 mm
Dome-Ø	53 mm
Offset	25 mm
Swivel Interference	155 mm
Overall height	69 mm
Temperature	- 25 / - 25 °C
Standard	EN_12530
Weight	0.356 kg
Swivel Radius	77 mm
Hardness of tread	Shore D 42
Load capacity	70 kg
Load capacity (static)	140 kg

## Dimensions

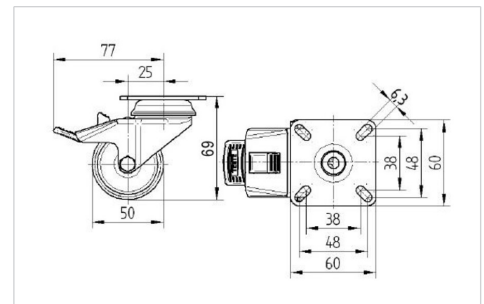

## Structure & Mounting

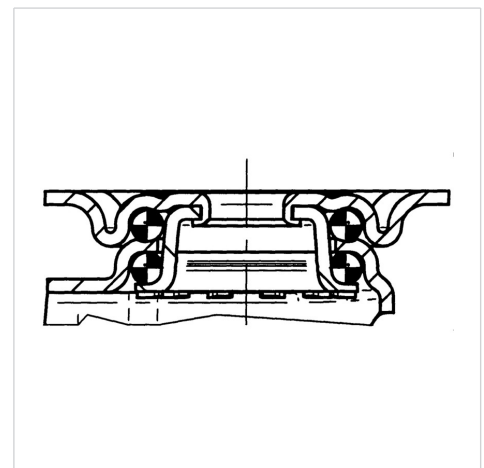

## Advantages at a glance

Roll performance	● ● ● ○ ○
Movement noise	● ● ● ○ ○
Attrition	● ● ● ● ○
Corrosion resistance	● ● ● ○ ○

# AGILA TWIN

2975UAK050P40

EAN 4031582302837



BETTER MOBILITY. BETTER LIFE.

## Structure & Mounting

