

AGILA TWIN

2975UAK050P30-11

EAN 4031582302820

Swivel castor with wheel brake, housing made of pressed steel, bright zinc plated, blue passivated, double ball bearing swivel head, wheel axle with nut, bolt hole. Wheel centre made of Polyamide, Tread: Polyurethane, with threadguards, cone ball bearing



BETTER MOBILITY. BETTER LIFE.



Picture may differ from original product

Technical Data

Wheel diameter	50 mm
Wheel width	20 mm
Castor width	57 mm
Centre hole	11 mm
Dome-Ø	53 mm
Offset	25 mm
Swivel Interference	155 mm
Overall height	69 mm
Temperature	- 25 / - 25 °C
Standard	EN_12530
Weight	0.324 kg
Swivel Radius	77 mm
Hardness of tread	Shore D 42
Load capacity	70 kg
Load capacity (static)	140 kg

Advantages at a glance

Roll performance	● ● ● ○ ○
Movement noise	● ● ● ○ ○
Attrition	● ● ● ● ○
Corrosion resistance	● ● ● ○ ○

Dimensions

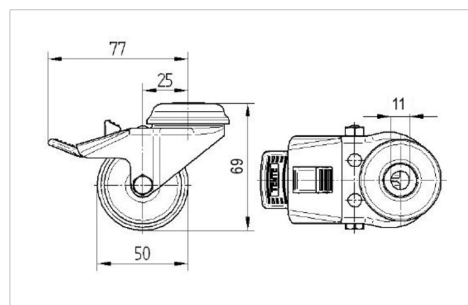

Structure & Mounting

