

AGILA

2477PJO075P30-11

EAN 4031582050363

Swivel castor with total lock, tail end of castor, housing made of pressed steel, bright zinc plated, blue passivated, double ball bearing swivel head, bolt hole. Wheel centre made of Polypropylene, Tread: TENTEprene (thermoplastic rubber), grey non-marking, plain bearing Castors can be mounted with standard screws of any length.



BETTER MOBILITY. BETTER LIFE.



Picture may differ from original product

Technical Data

Wheel diameter	75 mm
Wheel width	25 mm
Castor width	43 mm
Centre hole	11 mm
Dome-Ø	43 mm
Offset	24 mm
Swivel Interference	160 mm
Overall height	100 mm
Temperature	- 20 / + 60 °C
Standard	EN_12530
Weight	0.267 kg
Swivel Radius	80 mm
Hardness of tread	Shore A 87
Load capacity	75 kg
Load capacity (static)	150 kg

Advantages at a glance

Roll performance	● ● ● ○ ○
Movement noise	● ● ● ○ ○
Attrition	● ● ● ○ ○
Corrosion resistance	● ● ● ○ ○

Dimensions

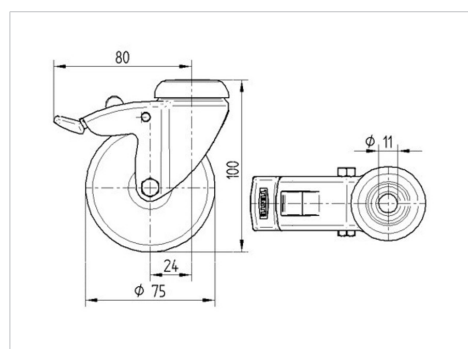

Structure & Mounting

