

SCOUT

814WUAC200P62 180°

EAN 4031582429121

Swivel castor, stainless steel housing with wheel brake and automatic directional stability, precision ball bearing in swivel bearing with long-life grease, swivel bearing with dust protection and grease nipple, wheel brake according to ball-pen principle, plate fitting Swivel castor with automatic directional stability and wheel brake, 托板安装装置。 Wheel centre made of polyamide, tread made of polyurethane, two INOX precision ball bearings, sealed, washable

TENTE

BETTER MOBILITY. BETTER LIFE.



Picture may differ from original product

技术数据

| | |
|---------|-----------------|
| 轮子直径 | 200 毫米 |
| 车轮宽度 | 40 毫米 |
| 脚轮宽度 | 74 毫米 |
| 托板尺寸 | 120 x 80 毫米 |
| 托板孔中心 | 80 x 60 毫米 |
| 托板孔 | 11 毫米 |
| 安装孔-直径 | 68 毫米 |
| 偏移量 | 50 毫米 |
| 旋转阻止 | 325 毫米 |
| 总高度 | 245 毫米 |
| 温度 | - 40 / + 80 摄氏度 |
| 标准 | similar_EN12532 |
| 重量 | 3.187 公斤 |
| 旋转半径 | 162.5 毫米 |
| 轮面硬度 | 支杆 A 92 |
| 动(力)载重量 | 350 公斤 |
| 静载重量 | 700 公斤 |

Advantages at a glance

| | |
|------|-----------|
| 滚动阻力 | ● ● ● ● ○ |
| 运动噪音 | ● ● ● ○ ○ |
| 磨损 | ● ● ● ● ○ |
| 防锈 | ● ● ● ○ ○ |

Dimensions

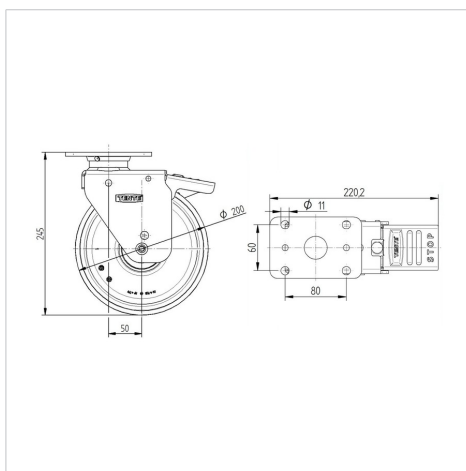

Structure & Mounting

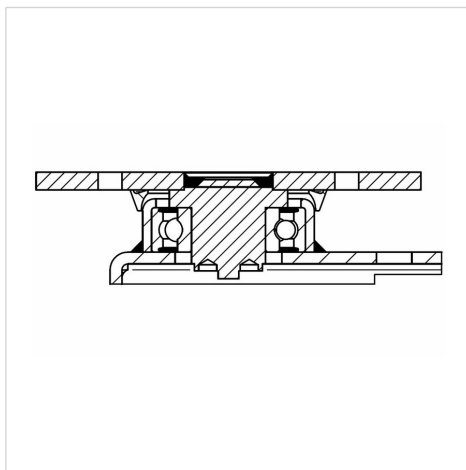

SCOUT

814WUAC200P62 180°

EAN 4031582429121



BETTER MOBILITY. BETTER LIFE.

Structure & Mounting

